

# DC20D MK2 GENSET CONTROLLER USER MANUAL



## Software Version

No.	Version	Date	Note
1	V1.0	2020-08-01	Original release.
2	V1.1	2019-03-01	1) Optimization of over current inverse time function. 2) Add over-current fault delay function.
3	V1.2	2020-05-01	Add RS485 communication baud rate and CRC check bit setting;
4	V1.3	2021-02-01	Name of unified input and output port.
5	V1.4	2021-06-01	Fix known errors in wiring diagram. .



Chongqing MEBAY Technology Co.,Ltd

Add: No6-2,Building 4, Gangan Rd, Jiangbei District, Chongqing.

Tel: +86-23-6869 3061



Fax: +86-23-6765 8207

Web: <http://www.mebay.cn>

<http://www.cqmb.cn>

E\_mail: [sales@mebay.cn](mailto:sales@mebay.cn)

## Symbol Description

Symbol	Description
 Note	Remind operators to operate correctly, otherwise it may cause the equipment not to work correctly.
 Be care	It is indicated that potential hazards can damage equipment without proper precautions.
 Warning	It is indicated if appropriate preventive measures are not taken, potentially dangerous situations may result in death, serious personal injury or significant property losses.

**Warning**

1. The installation of this equipment must be carried out by professionals.
2. When installing and operating the controller, please read the entire instruction manual first.
3. Any maintenance and commissioning of the equipment must be familiar with all the equipment.
4. t, safety standards and precautions in advance, otherwise it may cause personal injury or damage to related equipment.
5. The engine must have an overspeed protection device independent of the controller system to avoid casualties or other damage caused by engine out of control.
6. After the installation of the controller is completed, please verify that all protection functions are valid.

**Be Care**

1. Please keep the good connection of the power supply of the controller. Do not share the connection lines of the positive and negative electrodes of the battery with the floating charger.
2. During the operation of the engine, do not disconnect the battery, otherwise it may cause damage to the controller.

## CATALOGUE

1. Summary .....	5
2. Main Features .....	5
3. Parameters Display .....	5
4. Protection .....	5
5. Parameters .....	6
6. Overall Dimension and Wiring Diagram .....	7
7. Installation instruction .....	10
8. Panel and display .....	11
9. Control and operation instruction .....	12
10. Warnings and Shutdown Alarms .....	14
11. Parameters setting .....	18
12. Fault finding .....	23

### Notes:

1. All rights reserved. No part of this duplication may be reproduced in any material form (including photocopying or storing in any medium by electronic means or others) without the written permission of the copyright holder.
2. MEBAY Technology reserves the rights to change the contents of this document without prior notice.

## 1. Summary

DC20D MK2 is one module used for Diesel/gasoline Generator, It's an upgraded product of DC20D. It is with the functions of Auto Star/Stop, Protection and Alarm indication. DC Power and Running situation is indicated on the front panel.

The status of the engine and generator can be checked conveniently because these parameters of over speed, under speed, Over Frequency, Low Frequency, Over Voltage, Under Voltage, Low Oil Pressure, High Temperature, Low Water Level, Low Oil Level, Charge Failure, Over-time Stop, Emergency Stop Alarm System as well as Low Battery Voltage can be indicated in time.

The output connector is connected with traditional relay which can burden more output current. The parameters can also be set by the front face buttons so that it can be used in different kinds of situations.

## 2. Main Features

- ◆ Dual core 32bit high performance single chip microcomputer.
- ◆ 5 Units LED tube Display.
- ◆ LED and Fault Alarm Code Indication.
- ◆ Totally 4 relay's output, among which 2 relay output can be self-configurable, each relay can be set as max 6 functions.
- ◆ It has two sensors and three switch inputs (input channels 2 and 3 can be configured as sensors or switch inputs);
- ◆ With RS485 communication port, can achieve "Three Remote" functions via MODBUS protocol.
- ◆ Various of crank conditions (RPM, Frequency, Oil Pressure) can be chosen.
- ◆ Sensor can be self-defined by PC software.
- ◆ Control Protection: Auto Start/Stop of genset, perfect failure display and protection.
- ◆ Standard water-proof rubber gasket, The waterproof can reach IP54.
- ◆ Module design: All the connections are adapted with European connectors so that installation, connection, repair and replacement can be more easily.

## 3. Parameters Display

- ◆ Engine RPM
- ◆ Generator Frequency Hz
- ◆ Generator Phase voltage L-N
- ◆ Generator current A
- ◆ Engine battery voltage
- ◆ Running time
- ◆ Accumulation time
- ◆ Engine water temperature
- ◆ Engine oil pressure

## 4. Protection

- ◆ Emergency Stop
- ◆ Over frequency stop
- ◆ Under frequency stop
- ◆ Over voltage stop
- ◆ Under voltage stop
- ◆ Over current stop

- ◆ Low Oil Pressure Stop
- ◆ High water temperature stop
- ◆ Oil pressure sensor Open
- ◆ Water temperature sensor Open
- ◆ Start Failure
- ◆ Stop Failure
- ◆ Low Water level stop
- ◆ Low Water level stop
- ◆ High Oil temperature stop
- ◆ RPM signal lost alarm
- ◆ Over speed stop
- ◆ Under speed stop
- ◆ Low Fuel Level warning
- ◆ Low Battery voltage warning

## 5. Parameters

Options	Parameters
Working voltage	DC8V----36V Continuous
Power consumption	Standby: 24V: MAX 1W
	Working: 24V: MAX 3W
AC Voltage Input	1P2W 30VAC-450VAC (ph-N)
Rotate speed sensor Frequency	30-9999Hz
MAX Accumulating Time	99999.9Hours (Min Store time:6min)
Fuel Relay Output	Max 5 Amp DC+VE Supply voltage
Start Relay Output	Max 5 Amp DC+VE Supply voltage
AUX. OUTPUT 1	Max 2.5 Amp DC+VE Supply voltage
AUX. OUTPUT 2	Max 2.5 Amp DC+VE Supply voltage
Excitation output	Max 1AMP DC+VE supply voltage
Switch value input	Available if connecting with Battery -
Working condition	-30-70°C
Storage condition	-40-85°C
Protection Level	IP65: when waterproof rubber gasket is added between controller and its panel
Insulation strength	Apply AC1.5kV voltage between high voltage terminal and low voltage terminal; The leakage current is not more than 3mA within 1min.
Overall dimension	78mm*78mm*55mm
Panel cutout	67mm*67mm
Weight	0.3Kg

6. Overall Dimension and Wiring Diagram

◆ Overall Dimension:

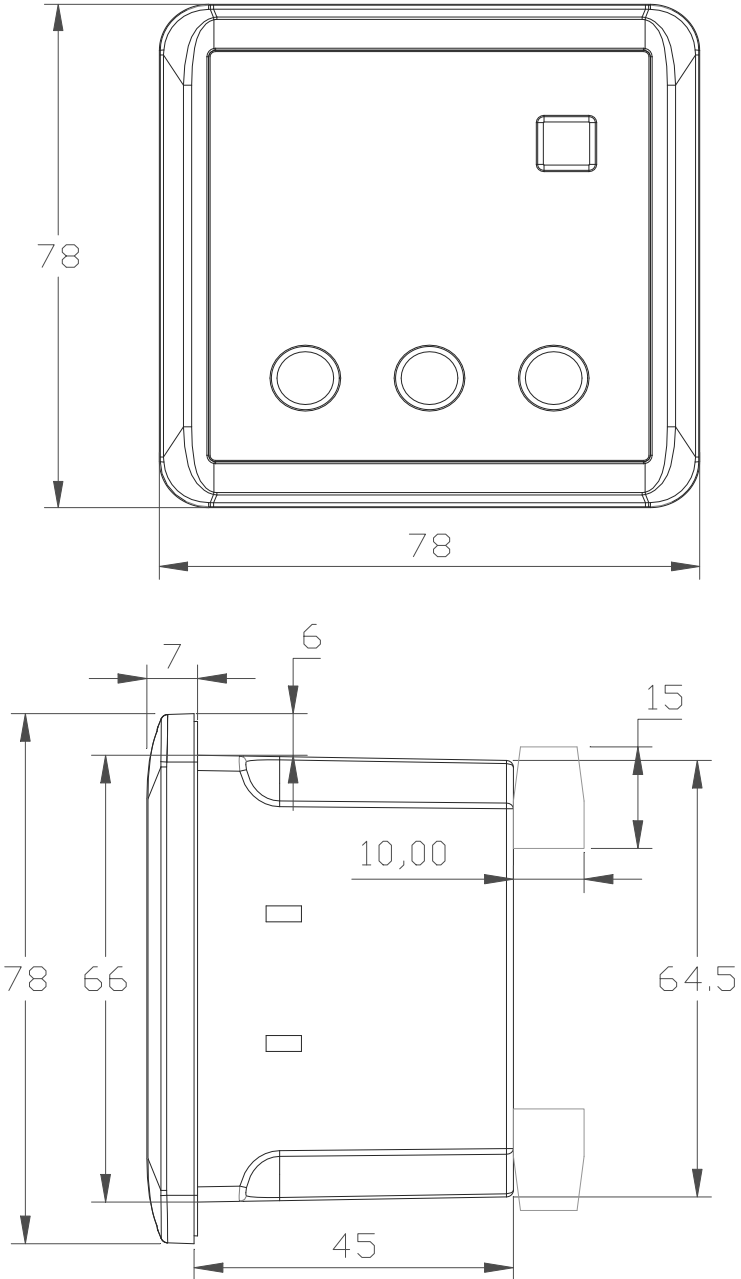

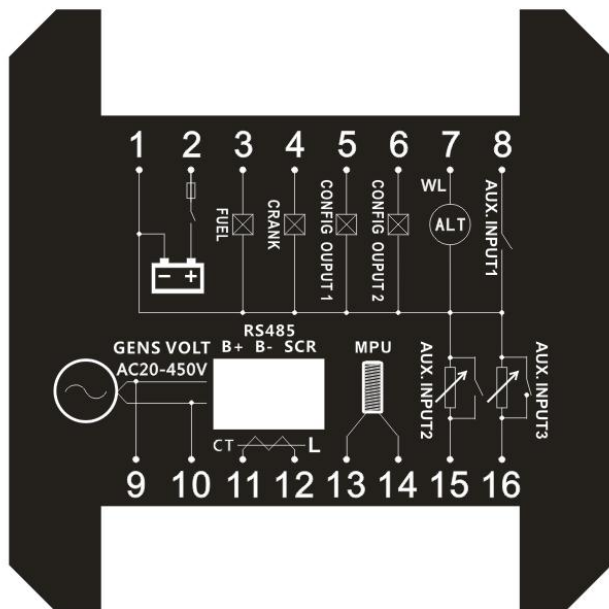

**◆ Descriptions of terminal connection**

No.	Function	Description	Cable cross sectional area
1	Battery Negative Input B-	Controller power supply input B-.	2.5mm <sup>2</sup>
2	Battery Negative Input B+	Controller power supply input B+.	2.5mm <sup>2</sup>
3	Fuel Output	+VE output, Max 5 Amp	1.5mm <sup>2</sup>
4	Crank Output	+VE output, Max 5 Amp.	1.5mm <sup>2</sup>
5	Aux. Output 1	+VE output, Max 2.5 Amp.	1.5mm <sup>2</sup>
6	Aux. Output 2	+VE output, Max 2.5 Amp.	1.5mm <sup>2</sup>
7	Charging excitation output	+VE output, Max 0.9 Amp.	1.0mm <sup>2</sup>
8	Aux. Input 1	Switch input, Connect to the negative side of the active circuit.	1.0mm <sup>2</sup>
9	Generator Voltage L	Connect to generator set output L line	1.0mm <sup>2</sup>
10	Generator Voltage N	Connect to generator set output N line	1.0mm <sup>2</sup>
11	Load CT Secondary	Connected to the secondary of current transformer, 0-5A input.	1.0mm <sup>2</sup>
12	Load CT Secondary		1.0mm <sup>2</sup>
13	Speed sensor -	Connect sensor input. Use a shielded wire to connect the speed sensor.	1.0mm <sup>2</sup>
14	Speed sensor +		1.0mm <sup>2</sup>
15	Aux. Input 2	Switch input or sensor input (to be configured)	
16	Aux. Input 3	Switch input or sensor input (to be configured)	

◆ DC20D MK2 Typical Wiring Diagram

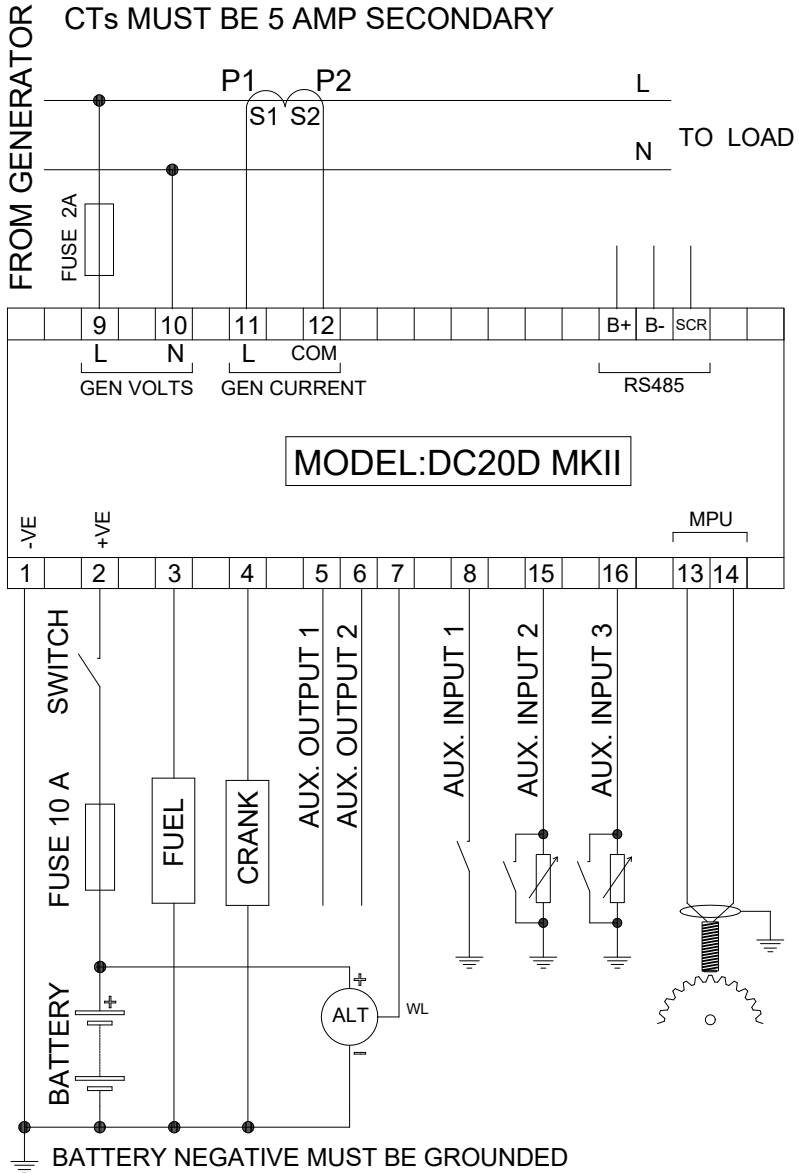

**!** *Note: Please don't move battery during running status or it may cause the controller broken!*

**⚠** **WARNING:** When generator is on-load, C. T. secondary must not be open circuit, Otherwise, the high voltage generated will pose a danger to personal safety.

## 7. Installation instruction

- ◆ The controller is fixed by four special fixing members and screws, and the screws of the metal fasteners cannot be too tight.
- ◆ Panel Cutout: W67mm\*H67mm.

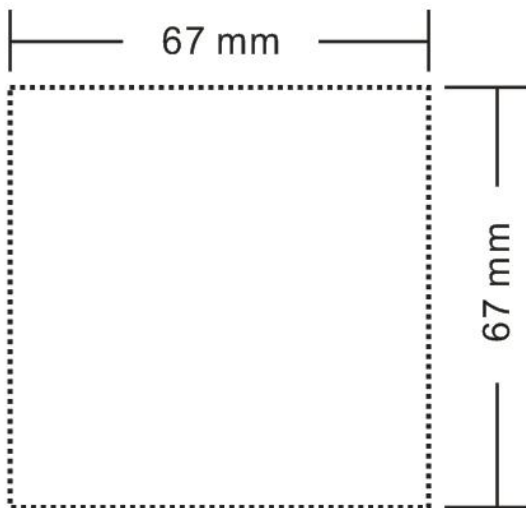

**Note:** If the controller is installed directly in the genset shell or other fluctuated equipment, the rubber pad must be installed.

### ◆ Battery Voltage Input

DC20D MK2 controller is suitable for 8-36V DC battery voltage. Battery negative must be reliably connected to the enclosure of the engine. The controller power supply B+ and B- must be connected to battery positive and negative, and the wire size must not be less than 2.5mm<sup>2</sup>.



NOTE:

In case of floating charger connect charger output to battery positive and negative directly, then, connect battery positive and negative poles to controller positive and negative power supply.

### ◆ Output and relay expansion



Note: All outputs of the controller are relay contacts. The maximum current capacity is described in the "Parameters" in this manual. Please use it in the relay current capacity. If an extended relay is needed, add a continuous current diode (when the extended relay coil is DC) or a resistance-capacitance loop (when the extended relay coil is AC) to both ends of the coil to prevent interference with the controller or other equipment.

### ◆ AC current input

Current transformer with rated secondary current 5A must be externally connected to the controller current input.



**WARNING:** When generator is on-load, C. T. secondary must not be open circuit, Otherwise, the high voltage generated will pose a danger to personal safety.

◆ **Withstanding voltage test**



If withstanding voltage test is conducted after the controller has already been installed onto the control panel, please unplug all controller terminal connections in order to prevent high voltage from damaging it.

**8. Panel and display**

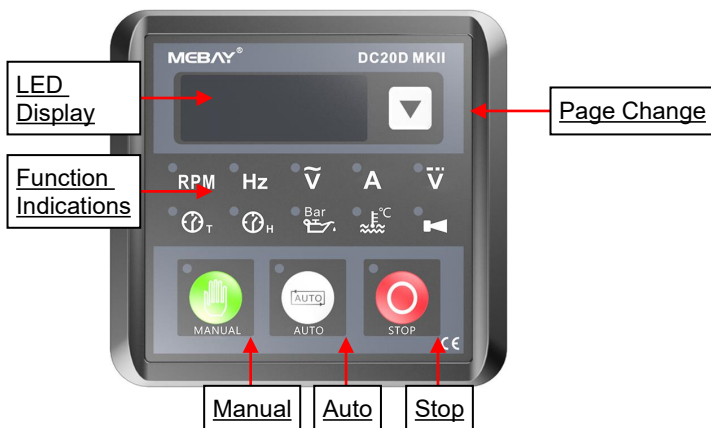



◆ **Key Function Description**

KEYS	NAME	Main Function
	Stop Reset Revert	<ul style="list-style-type: none"> <li>◆ Can stop generator under manual/auto mode;</li> <li>◆ Can reset shutdown alarm</li> <li>◆ During stop procession, pressing this key again can stop generator immediately.</li> <li>◆ Pressing this key can cancel the setting and back to upper class under edition.</li> <li>◆ Parameters to be saved under value checking page.</li> </ul>
	Manual	<ul style="list-style-type: none"> <li>◆ Pressing this key will set the module into manual mode.</li> <li>◆ Under display mode, parts of the page can move down.</li> <li>◆ Under edition mode, to move the digit or decrease the numbers.</li> </ul>
	Auto	<ul style="list-style-type: none"> <li>◆ Pressing this key will set the module into auto mode.</li> <li>◆ Under display mode, parts of the page can move up.</li> <li>◆ Under edition mode, to move the digit or increase the numbers.</li> </ul>
	Page Change	<ul style="list-style-type: none"> <li>◆ Change the display page.</li> <li>◆ Under display mode, Confirm the change under edition mode.</li> </ul>

**9. Control and operation instruction**

**◆ Manual Start Mode**

press  and make sure it is in the stop position before starting.

Press  and the test file indicator is on. At this time, it is detected whether the connection of each sensor is normal. If the sensor is open, the sensor opens an alarm. If it is normal, the unit start process is executed in the following sequence. automatically switch to Generator provide the power when the unit is running

normally. Press  The controller performs the parking process at the following timing:

Manual start and stop process:

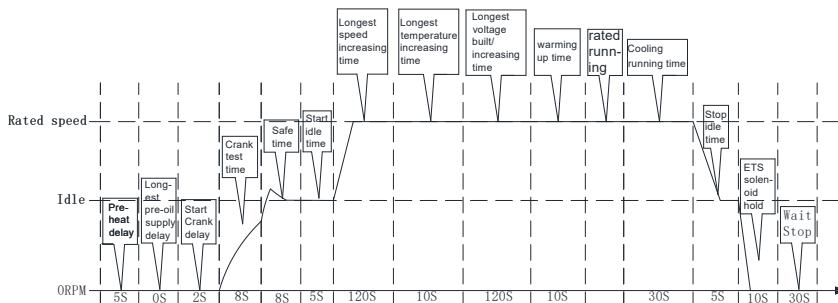

After the manual start is successful, pressing the "automatic key"  can be converted into an automatic file. The specific working time is as follows:

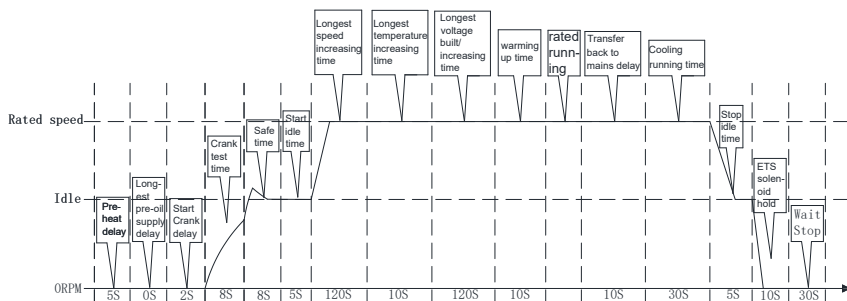

**Automatic starting mode:**

press  and make sure it is in the stop position before starting.

Press  and the test file indicator is on. At this time, it is detected whether the connection of each sensor is normal. If the sensor is open, the sensor opens an alarm. If it is normal, wait for the remote start signal to be valid detected the remote starting signal is valid. The genset will perform the starting process in the following sequence. When the genset enters the normal rated operation, it will automatically switch to the generator provide the power. The controller will detect the remote start signal in real time. When the remote start signal fails to normal, the shutdown

process after the "loop time delay" is performed.

Auto start and stop process:

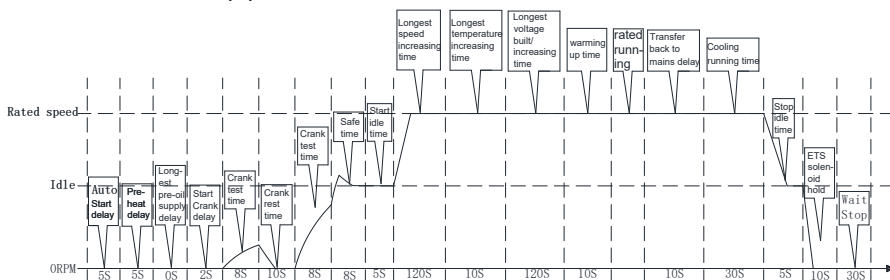

◆ **Notices in Starting Process**



Note 1: During the Cranking time, the controller automatically detects the speed signal, frequency signal and oil pressure value or the charging voltage (according to the parameter setting) to reach the judgment condition of successful start, then the judgment is that the start is successful and the motor relay is closed.



Note 2: Within the safety delay, only respond to emergency stop, over speed, over frequency, over voltage, Speed signal lost, low fuel level warning, other alarms are not responded to.



Note 3: No response to alarm and warning of under speed, low frequency, under voltage, over current, during start idle time.



Note 4: After entering the speed up time, the high-speed relay outputs (if the idle speed output is configured, if the idle speed output is not configured, then there is no such time), and the response alarm within this time is consistent with the starting idle time; within this time, if the speed reaches more than 90% of the "rated speed", then the "speed up time" is ended;



Note 5: No response to low frequency, under voltage, over current when entering the Voltage-up time.



Note 6: After entering rated operation, the Gens load relay output.



Note 7: In the process of shutdown, if the remote starting signal is restored to be valid within the "Cooling time", the rated operation will be entered again.



Note 8: If the stop key is pressed again during idle time, the idle time will be canceled and the stop operation will be executed directly.

## 10. Warnings and Shutdown Alarms

### ◆ Warnings



Notes: Warning is a non-serious failure state, which will not harm the gensets system for the time being. It only reminds operators to pay attention to the situation that does not meet the requirements and solve it in time to ensure the continuous operation of the system. When the warning occurs, the gensets does not stop. Once the fault is removed, the warning is automatically canceled.

When a warning fault occurs, the public alarm indicator  is always on, and the current fault interface displays warning instructions, but the machine does not stop.

#### Low fuel level switch warning

When the controller detects that the AUX. INPUT "**Low fuel level warning input**" switch is active, it starts warning delay and lasts for Normal alarm delay. When the "**Low fuel level warning input**" switch is enabled, the engine low fuel level switch warning is reported. Warning lights  will light up, Generators will not stop, displays "**ALA.09**" on the led screen.

#### Under battery voltage warning

When the controller detects that the battery voltage is lower than the "**Under battery voltage warning**", Then start warning delay and the duration (Normal alarm delay) have not returned to normal, the warning of Under battery voltage warning is reported.

Warning lights  will light up, Generators will not stop, displays "**ALA.12**" on the led screen.

### ◆ Starting fault

#### Oil pressure sensor disconnected alarm

When the controller parameter "**Action if low oil pressure sensor disconnected**" is set to "**alarm**", When the oil pressure sensor is detected to be disconnected,Then start alarm delay and the duration (Normal alarm delay) have not returned to normal,

the alarm of Oil pressure sensor disconnected alarm is reported. Alarm lights  will light up, Generators will stop, displays "**ALA.13**" on the led screen.

#### Temperature sensor disconnected alarm

When the controller parameter "**Action if temperature sensor disconnected**" is set to "**alarm**", When the temperature sensor is detected to be disconnected,Then start alarm delay and the duration (Normal alarm delay) have not returned to normal, the

alarm of temperature sensor disconnected alarm is reported. Alarm lights  will light up, Generators will stop, displays "**ALA.14**" on the led screen.

#### Fail to Start

If the number of cranks exceeds the predetermined number of cranks, the failure of start-up will be reported if the start-up of the generating unit is still unsuccessful.

Alarm lights  will light up, Generators will stop, displays "**ALA.20**" on the led screen.

### ◆ Shutdown Alarms



Warning: After the Shutdown Alarm occurs, the system will be locked immediately and the generator set will be stopped. Only after troubleshooting, press  key to clear the alarm, can it be re-operated.



Notes: When the shutdown alarm failure occurs, the "**ALARM**" lights will light up and the generator unit automatically stops.

### Emergency stop alarm

When the controller detects that the emergency stop input is grounded,, then start alarm delay and the duration (Emergency delay) have not returned to normal, the

alarm of Emergency Stop is reported. Alarm lights  will light up, Generators will stop, displays "**ALA.01**" on the led screen.

### Over speed alarm

When the controller detects that the engine speed is higher than "**Over speed alarm**", Then start alarm delay and the duration (Emergency delay) have not returned to

normal, the alarm of over speed is reported. Alarm lights  will light up, Generators will stop, displays "**ALA.02**" on the led screen.

### Under speed alarm

When the controller detects that the engine speed is under than "**Under speed alarm**", Then start alarm delay and the duration (Normal alarm delay) have not

returned to normal, the alarm of under speed is reported. Alarm lights  will light up, Generators will stop, displays "**ALA.03**" on the led screen.

### Low oil pressure sensor alarm

When the controller detects that the engine Oil Pressure is lower than "**Low oil pressure alarm**", Then start alarm delay and the duration (Normal alarm delay) have not returned to normal, the alarm of low Oil Pressure is reported. Alarm lights

 will light up, Generators will stop, displays "**ALA.04**" on the led screen.

### Low oil pressure switch alarm

When the controller detects that the AUX. INPUT port "**Low oil pressure alarm input**" switch is active. Start low oil pressure switch alarm delay, for a period of time "Normal alarm delay", AUX. INPUT port "low oil pressure alarm input" switch is valid.

Alarm lights  will light up, Generators will stop, displays "**ALA.05**" on the led



screen.

### High Coolant Temperature Sensor Alarm

When the controller detects that the coolant temperature value is higher than the "**High coolant temperature alarm**", Then start alarm delay and the duration (Normal alarm delay) have not returned to normal, the alarm of High coolant temperature

alarm is reported. Alarm lights  will light up, Generators will stop, displays "**ALA.06**" on the led screen.

### High Coolant Temperature Switch Alarm

When the controller detects that the High temperature alarm switch input is valid to the ground, then start alarm delay and the duration (Normal alarm delay) have not returned to normal, the alarm of High Temperature Switch is reported. Alarm lights

 will light up, Generators will stop, displays "**ALA.07**" on the led screen.

### High Oil Temperature Switch Alarm

When the controller detects that the High temperature alarm switch input is valid to the ground, then start alarm delay and the duration (Normal alarm delay) have not returned to normal, the alarm of High Temperature Switch is reported. Alarm lights

 will light up, Generators will stop, displays "**ALA.08**" on the led screen.

### Low coolant level switch alarm

When the controller detects that the AUX. INPUT "**Low water level alarm**" switch is active, it starts alarm delay and lasts for Normal alarm delay. When the "**Low water level alarm**" switch is enabled, the engine low coolant level switch alarm is reported.

Alarm lights  will light up, Generators will stop, displays "**ALA.10**" on the led screen.

### Speed signal lost alarm

When the controller parameter "**Action if RPM lost**" is set to "**alarm**", the detected speed value is 0, Then start alarm delay and the duration (Normal alarm delay) have not returned to normal, the alarm of speed signal lost warning is reported. Alarm

lights  will light up, Generators will stop, displays "**ALA.11**" on the led screen.

### Over frequency alarm

When the controller detects that the generator frequency is higher than "**Over frequency alarm**", Then start alarm delay and the duration (Emergency delay) have

not returned to normal, the alarm of over frequency is reported. Alarm lights  will light up, Generators will stop, displays "**ALA.15**" on the led screen.

### Under frequency alarm

When the controller detects that the generator frequency is lower than "**Under**

**frequency alarm**", Then start alarm delay and the duration (Normal alarm delay) have not returned to normal, the alarm of under frequency is reported. Alarm lights



will light up, Generators will stop, displays "**ALA.16**" on the led screen.

### Over voltage alarm

When the controller detects that the generator voltage is higher than "**Over voltage alarm**", Then start alarm delay and the duration (Normal alarm delay) have not

returned to normal, the alarm of over voltage is reported. Alarm lights  will light up, Generators will stop, displays "**ALA.17**" on the led screen.

### Under voltage alarm

When the controller detects that the generator voltage is lower than "**Under voltage alarm**", Then start alarm delay and the duration (Normal alarm delay) have not

returned to normal, the alarm of under voltage is reported. Alarm lights  will light up, Generators will stop, displays "**ALA.18**" on the led screen.

### Over current alarm

When the controller detects that the generator phase current is higher than "**Phase current over-load alarm**", Then start alarm delay and the duration (Normal alarm delay) have not returned to normal, the alarm of over current is reported. Alarm lights



will light up, Generators will stop, displays "**ALA.19**" on the led screen.

### Stop failure with speed alarm

When the controller detects that the **speed** is not "0" after the execution of the

shutdown, the alarm of stop failure is reported. Alarm lights  will light up, Generators will stop, displays "**ALA.21**" on the led screen.

### Stop failure with frequency alarm

When the controller detects that the frequency is not "0" after the execution of the

shutdown, the alarm of stop failure is reported. Alarm lights  will light up, Generators will stop, displays "**ALA.22**" on the led screen.

### Stop failure with oil pressure alarm

When the controller detects that the Oil **Pressure** is not "0" after the execution of the

shutdown, the alarm of stop failure is reported. Alarm lights  will light up, Generators will stop, displays "**ALA.23**" on the led screen.

### Stop failure with oil pressure switch



When the controller detects that the oil pressure switch has not returned after the



stop, it will alarm, alarm lights  will light up, Generators will stop, displays "**ALA.24**" on the led screen.





## 11. Parameters setting

### ◆ Enter the edition page

Please set the parameters according to below steps:

1) In the stop mode, please  and  simultaneously, then loose, Then system comes into menu setting.

2) Press  to shift up the parameters, press  to shift down the parameters, press  to get into parameter changing page.

3) Press  to add number, press  to reduce number, press  cancel. The value can be increased or decreased continuously when pressing the button continuously. Press  to confirm the value modification.

4) Under display mode, press  to exit and save data.

 **Note: the data can not be saved if the user didn't press STOP to confirm the setting.**

### ◆ Parameter setting

No	Parameter	Range (default)	Notes
0	CT rate	5-6000A/5A(500A/5A)	Used for setting genset CT primary current, secondary rated current 5A.
1	Flywheel teeth	0-300(0)	If the setting is 0, (RPM sensor Disabled), then RPM is resulted by Hz.
2	AUX. INPUT 1 (Functional of PIN 8)	0- Disable. 1- <b>Emergency stop.</b> 2- Remote start switch. 3- Low oil pressure alarm switch. 4- High Coolant temperature alarm switch. 5- High oil temperature alarm switch. 6- Low fuel level warning switch. 7- Low water level alarm switch.	Choose the programmable input 1, only for switch value input
3	AUX. INPUT 2 (Functional of PIN 15)	0- Disable. 1- Emergency stop. 2- Remote start switch. 3- Low oil pressure alarm switch. 4- High Coolant temperature alarm switch. 5- High oil temperature alarm switch. 6- Low fuel level warning switch.	Choose programmable input 2, switch value input or sensor simulation value input are available; if the sensors of users are not in the list, please self-define the sensor's resistance by connecting with PC.

		7- Low water level alarm switch. 8- 9 Reserved. <b>10- Oil pressure sensor VDO 0-10BAR.</b> 11-Oil pressure sensor DATCON 10Bar 12- Oil pressure sensor 3015237 10Bar 13- Oil pressure sensor User-defined(PC to configure )	
4	AUX. INPUT 3 (Functional of PIN 16)	0- Disable. 1- Emergency stop. 2- Remote start switch. 3- Low oil pressure alarm switch. 4- High Coolant temperature alarm switch. 5- High oil temperature alarm switch. 6- Low fuel level warning switch. 7- Low water level alarm switch. 8- 9 Reserved. <b>10- Coolant temperature sensor VDO 40 ℃—120 ℃ .</b> 11-Coolant temperature sensor Datcon High. 12- Coolant temperature sensor 3015238 13- Coolant temperature sensor MEBAY-Mier. 14- Coolant temperature sensor User-defined (PC to configure )	Choose programmable input 3, switch value input or sensor simulation value input are available; if the sensors of users are not in the list, please self-define the sensor's resistance by connecting with PC.
5	Action if oil pressure sensor disconnected	0-Disable <b>1-Enable</b>	Action if oil pressure sensor disconnected.
6	Action if Coolant Temp. sensor disconnected	0-Disable <b>1-Enable</b>	Action if Coolant temperature sensor disconnected.
7	AUX. OUTPUT 1 (Functional of PIN 5)	0-6 <b>(3. Public alarm output )</b>	<b>0. Disable.</b> <b>1. E.S.T. hold:</b> shutdown output, it is used for gens with stop solenoid.

8	AUX. OUTPUT 2 (Functional of PIN 6)	0-6 <b>(4. Preheat)</b>	<p>when the setting value of shutdown delay is over, then it is off.</p> <p><b>2. Idle speed control:</b> used for speed controller, there is output under idle but no output under high speed.</p> <p><b>3. Public alarm output:</b> when there is any alarm output, alarm locks till revert back.</p> <p><b>4. Preheat:</b> preheat output before start.</p> <p><b>5. Close generator;</b></p> <p><b>6. Choke control:</b> choke will be started after crank success and off after delay.</p>
9	Manual crank times	1-30( <b>1 time</b> )	Crank times under mode and test mode.
10	Auto start crank times	1-30( <b>3 times</b> )	Crank times under auto mode.
11	Auto mode E.T.S. hold times	1-3 ( <b>2 times</b> )	The max E.T.S. hold on power shall be canceled once stop success under auto mode . The output interval time is " Fail to stop ".
12	Crank disconnect	<b>0.</b> RPM <b>1.</b> Hz <b>2. RPM/Frequency</b> <b>3.</b> RPM/Oil Pressure <b>4.</b> Frequency/Oil Pressure <b>5.</b> RPM/Freq./Oil Pressure	Either of the conditions can be acceptable as crank condition. But all of them should be meet together to regard as stop condition.
13	RPM disconnect	350-999RPM( <b>380RPM</b> )	When the engine RPM is over the condition value, then system regards it as crank success, motor escaped.
14	Frequency disconnect	10.0~40.0Hz ( <b>21.0Hz</b> )	When the gens frequency is over the condition value, then system regards it as crank success.
15	Oil pressure disconnect	0.1~10.0Bar ( <b>2.0Bar</b> )	When the engine oil pressure is over the condition value, then system regards it as crank success, motor escaped.
16	E.T.S. hold time	0~240s ( <b>10s</b> )	Stop solenoid on power time.
17	Start delay	0~240s ( <b>5s</b> )	The time during the genset starts after the remote start signal is valid.
18	Preheat time	0~240s ( <b>2s</b> )	The time needed to be preheat before the starter on power.
19	Cranking time	3~60s ( <b>10s</b> )	The time when the starter is on power.
20	Crank rest time	3~60s( <b>10s</b> )	If crank failure, the waiting time before the second test time.
21	Safety delay	1~60s ( <b>8s</b> )	Low oil pressure, high coolant temperature, under speed, under

			frequency, under voltage, charge failure are all invalid during this time except for emergency stop ,over speed and emergency stop.
22	Idle time	0~240s <b>(5s)</b>	Idle running time when crank successfully and before engine stop.
23	Cooling time	0~999s <b>(30s)</b>	After unloading, the time of cooling down by radiator before stop. during the delay, if the remote start signal is valid, then genset will come into rated running.
24	Fail to stop	10~60s <b>(60s)</b>	If the RPM, frequency and oil pressure is 0 during the stop failure time, then the stop failure time is no needed.
25	Emergency delay	0-10s <b>(1s)</b>	Emergency, over speed and over frequency alarm delay.
26	Normal alarm delay	2-20s <b>(5s)</b>	The alarm delay except for Emergency, over speed and over frequency alarm.
27	Over current 【inverse time】	0.1-36.0 <b>(36.0)</b>	This option will not take effect until the [D-Over phase current delay] is set to 0. The overcurrent delay is inverse time, and the formula is $T=t((IA/IT) - 1)^2$ .
28	Oil pressure delay	0-3s <b>(1s)</b>	When the crank condition contains oil pressure, if the oil pressure is higher than the preset value and continue for few seconds, then it is regarded as crank success.
29	Choke close delay	0~999s <b>(10s)</b>	The choke close delay after crank success.
30	Gens AC system	0- 2 Poles <b>1- 4 Poles</b> 2- 6 Poles 3- 8 Poles	When the flywheel teeth is set as 0,the RPM will be resulted by frequency. Pole 2: 50Hz---3000RPM.Pole 4: 50Hz---1500RPM.Pole 6: 50Hz---1000RPM.Pole 8: 50Hz---750RPM
31	Low oil pressure alarm	0.1~10.0Bar <b>(1.0Bar)</b>	When the oil pressure is lower than the alarm value and comes into low oil pressure delay but still lower (normal alarm delay), then low oil pressure alarms. if the value is set as 0.1, then the low oil pressure alarm is disabled.
32	High coolant temperature alarm	50~150℃ <b>(95℃)</b>	When the water temperature is higher than the alarm value and comes into high temperature delay but still higher (normal alarm delay), then high temperature alarms. if the value is set as 150, then the high temperature alarm is disabled.
33	Under battery voltage	0~28.0V <b>(8.0V)</b>	When the battery input is lower than the warning value and comes into

	warning		under battery voltage delay but still lower (normal alarm delay), then under battery voltage warns. <b>If the value is set as 0, when coming into parameters setting, then all the parameters can be set as defaults.</b>
34	Over freq alarm	50.0~70.0Hz ( <b>57.0Hz</b> )	When the RPM is higher than the alarm value and comes into over speed delay but still higher(emergency delay), then over speed alarms. if the value is set as 70.0, then the over speed alarm is disabled.
35	Under freq alarm	0~60.0Hz ( <b>30.0Hz</b> )	When the Freq is lower than the value and comes into under freq delay but still lower (emergency delay), then under frequency alarms. If the value is set as 0, then the alarm is disabled.
36	Over voltage alarm	100~500V ( <b>260V</b> )	When the voltage is higher than the value and comes into over voltage delay but still higher (normal alarm delay), then over voltage alarms. If the value is set as 500, then the alarm is disabled.
37	Under voltage alarm	50~380V ( <b>100V</b> )	When the voltage is lower than the value and comes into under voltage delay but still lower (normal alarm delay), then under voltage alarms. If the value is set as 0, then the alarm is disabled.
38	Under volts/ Under speed/ Under freq. in Manual Mode	0-Disable <b>1-Enable</b>	Choose if you need to start these functions under manual mode
39	Primary Modes	<b>0- STOP</b> 1- Manual 2- Auto 3- Auto save	The primary modes on power, easy for user operation. Note: auto record function can not record the mode with load.
A	Over speed alarm	0~4500RPM <b>(1710RPM)</b>	When the RPM is higher than the alarm value and comes into over speed delay but still higher(emergency delay), then over speed alarms. if the value is set as 4500, then the over speed alarm is disabled.
B	Under speed alarm	0~4500RPM <b>(1200RPM)</b>	When the RPM is lower than the alarm value and comes into under speed delay but still lower (normal alarm delay), then under speed alarms. if the value is set as 0, then the under speed alarm is disabled.

C	Over current alarm	1-2000A ( <b>500A</b> )	When the current is higher than the value and comes into over current delay but still higher (over current delay), then over current alarms. If the value is set as 2000, then the alarm is disabled.
D	Over phase current delay	0-3600.0s( <b>1296s</b> )	When this parameter is set to 0, the over current delay is the inverse time; if not, the over current delay is the time set for this parameter.
E	485 baud rate	0-4800 1-9600 <b>2-19200</b> 3-38400 4-57600 5-115200	RS485 communication baud rate selection.
F	485 CRC setting	0-CRC L_H <b>1-CRC H_L</b>	Sequence selection of RS485 communication protocol CRC;

## 12. Alarm code

Code	Meaning	Code	Meaning
ALA.01	Emergency stop alarm	ALA.13	Pressure sensor disconnected alarm
ALA.02	Over speed alarm	ALA.14	Coolant temperature sensor disconnected alarm
ALA.03	Under speed alarm	ALA.15	Over frequency alarm
ALA.04	Low oil pressure alarm-sensor	ALA.16	Under frequency alarm
ALA.05	Low oil pressure alarm-switch	ALA.17	Over voltage alarm
ALA.06	High coolant temperature alarm-sensor	ALA.18	Under voltage alarm
ALA.07	High coolant Temperature alarm-switch	ALA.19	Over current alarm
ALA.08	High oil temperature alarm-switch	ALA.20	Start failure alarm
ALA.09	Low fuel level warning-switch	ALA.21	Stop failure alarm-RPM
ALA.10	Low coolant level alarm-switch	ALA.22	Stop failure alarm-Frequency
ALA.11	Speed lost alarm	ALA.23	Stop failure alarm-Oil pressure sensor
ALA.12	Low battery voltage warning	ALA.24	Stop failure alarm-Oil pressure switch

## 13. Fault finding

Symptoms	Possible Solutions
Controller no response with power	Check DC voltage. Check DC fuse. Check if the terminal 1 and 2 is with battery voltage.
Genset shutdown	Check the water temperature is too high or not.



	<p>Check the genset AC voltage. Check DC fuse.</p>
Genset Emergency Stop	<p>Check the emergency stop button. Check the controller connection.</p>
Low oil pressure alarm	<p>Check oil pressure sensor and its wiring. Check the oil pressure sensor type and controller settings must be consistent. Check whether the low oil pressure sensor is normal.</p>
High temperature alarm	<p>Check temperature sensor and its wiring. Check the temperature sensor type and controller settings must be consistent. Check whether the temperature sensor is normal.</p>
Shutdown Alarm in running	<p>Check related switch and its connections according to the information on LED. Check AUX. INPUT.</p>
Fail to start	<p>Check fuel return circuit and wiring. Check start battery. Consult engine manual.</p>
Starter motor does not respond	<p>Check the wiring to the starter. Check start battery.</p>
Unit operation but ATS does not switch	<p>Check the ATS. Check the cable between the controller and the ATS.</p>
RS485 cannot communicate normally	<p>Check the connection. Check if the communication ID number setting is correct. Check if the A and B lines of RS485 are reversed. Check if the RS485 communication line driver is installed or not. Check if the communication port of the PC is damaged. Add a 120 Ω resistor between the AB of the controller RS485.</p>